

# Bolt-On Flooded Cell Range

Century motive industrial batteries PZV and PZS products are designed to DIN Standard. The PZV range incorporates Gel Valve Regulated Lead Acid technology. Ideally suited for environments where high levels of operational safety are required.

High manufacturing quality controls combined with unique design features provides these batteries with high cycle life and no electrolyte maintenance.

- Incorporating low antimony alloy on the positive grids reduces the ageing effects typically associated with higher antimony batteries. Where higher levels of antimony are used, which is released into the electrolyte and is deposited on the negative grid. When deposited it can have the effect increase the hydrogen evolution and increase the temperature during charging.
- Use of 'Red Lead' combined with strict manufacturing tolerances, improves the structure of the active material ensuring uniform capacity between plates. The use of Red Lead guarantees better control over the particle size and distribution of the active material within narrow tolerance limits.

- The pole bushing mechanism used on the PZV batteries is a robust 100% acid-tight connection of the pole and the lid. This unique sealing arrangement provides an extremely high level of acid protection to the terminal against acid leakage, a known failure in other product designs.
- The Century PZV battery incorporated a sleeve enveloping separator system that provides excellent electrolyte circulation and reduced movement material handling application, as well as providing excellent short circuit protection.
- Bolt-on terminals are designed to provide quick connection and disconnection of links during installation, and when required during maintenance.
- All Century motive industrial battery cells can be recycled. CenturyYuasa operate a recycling program to allow safe and environmentally disposal of lead acid batteries.

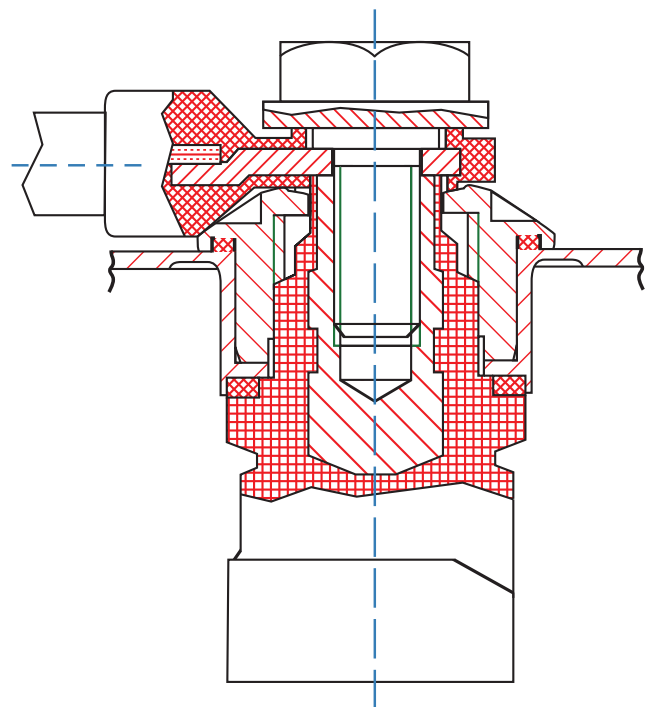
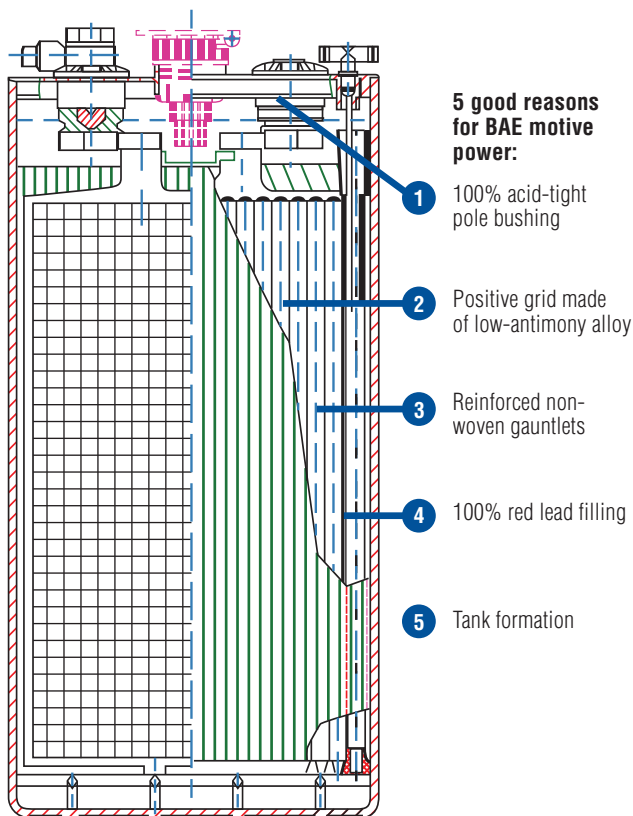

<sup>^</sup> Prolonged ambient temperature >35°C for lead acid technologies in material handling applications is a significant factor in reducing the service life of lead acid battery products.

# Bolt-On Flooded Cell Range

## SPECIFICATIONS FOR INDIVIDUAL CELL MODELS

Century Part Number	Cell	L (A) +/- 2mm	W (B) +/- 2mm	H (D) +/- 3mm	Overall H (C) Using GS Yuasa float cap +/-3mm	Cell Weight (kg)	5hr Capacity (Ah) @ 30 degree Celsius
510400	2PZS180L	47	198	475	505	12	180
511401	2PZS250E	47	198	570	600	14.9	250
511402	3PZS375E	65	198	570	600	21	375
512400	3PZS465F	65	198	720	750	26.9	465
511403	4PZS500E	83	198	570	600	26.5	500
512401	4PZS620F	83	198	720	750	34	620
511404	5PZS625E	101	198	570	600	32.6	625
512402	5PZS775F	101	198	720	750	42.1	775
511405	6PZS750E	119	198	570	600	38.5	750
512403	6PZS930F	119	198	720	750	48.3	930

## SPECIFICATIONS FOR ALL CELL MODELS

Standard	DIN
Positive Plate	Robust tubular design including fleece gauntlet with integrated edge protection
Electrolyte	Diluted sulphuric acid
Self Discharge Rate	<3% per month
Colour of Lid	Grey
Colour of Jar	Black
Terminal type	Bolt-on M10
Brand on lid	None
Separator	Sleeve PE
Torque Setting	29 - 30 N.m

An affiliated business of the GS Yuasa Corporation, CenturyYuasa has over 80-years of supplying a range of stored energy solutions to the Australian market. An established network of sales and distribution offices throughout Australia and New Zealand has seen the business gain the trust and respect from its customers by focusing on quality products and exceptional customer service. The portfolio within CenturyYuasa includes a wide range of stored energy products and services, as well as identifiable brands and unique technologies for automotive, materials handling and standby power applications. Directly maintaining and operating two manufacturing centers in Australia and employing some 500 people, CenturyYuasa continues to be a leading Australian manufacturer of stored energy products.

### Product Specification Disclaimer

All reasonable care has been taken to ensure that the data presented in this document is accurate for the purpose for which it is presented. CenturyYuasa reserves the right to make changes to its products and information contained in this document without notice, and shall not be held liable for any loss or damage claimed to have arisen as a result of the use of this brochure.